

**BNTET**<sup>®</sup>

## Burner Product Manual



## **ABOUT BNTET®**



Zhengzhou Bona Heat Energy Equipment Co., Ltd is an innovative technology enterprise, which is focusing on the production, R & D and technical consulting services of burners, burner accessories, hot air furnace, and boiler related products.

Zhengzhou Bona Heat Energy Equipment Co., Ltd upholds the development and innovation consciousness, produces products with high-performance combustion technology.

### **Main Products:**

Gas Burner;

Oil Burner(Diesel/Light Oil Burner, Heavy Oil Burner);

Dual Fuel Burner(Diesel/Light Oil or Gas, Heavy Oil or Gas);

Multi Fuel Burner;

Low NOx Burner;

Coal Burner;

Rotary Kiln Burner;

Asphalt Mixing Plant Burner;

Hot Air Furnace, etc.

### **Applicable Industries:**

1. Cement and Mining: rotary kiln equipment, drying application.
2. Energy: boiler equipment, hot air furnace / hot blast stove.
3. Metal: steel, aluminum, copper, forging and heat treatment equipment.
4. Petroleum and Natural Gas: petrochemical furnaces, oil refinery, oil and gas plant process equipment (tracer, industrial burner).
5. Asphalt Mixing Plant, Incinerator, Foundry Machinery, Industrial Stoves, and other thermal machinery supporting equipment.

## Table of Contents

<b>Gas Burner, BNG, BNG P, BNG FC series</b>	<b>3 ~ 6</b>
<b>Diesel/Light Oil Burner, BNL, BNL DSG, BNL FC series</b>	<b>7 ~ 10</b>
<b>Heavy Oil Burner, BNH G, BNH F series</b>	<b>11 ~ 14</b>
<b>Dual Fuel, Light Oil &amp; Gas Burner, BNGL, BNGL P, BNGL FC series</b>	<b>15 ~ 18</b>
<b>Dual Fuel, Heavy Oil &amp; Gas Burner, BNGH P, BNGH FC series</b>	<b>19 ~ 20</b>
<b>Low NOx Burners Technology</b>	<b>21 ~ 21</b>
<b>Asphalt Mixing Plant Burner BNB Series</b>	<b>22 ~ 22</b>
<b>Rotary Kiln Burner, BNRK series</b>	<b>23 ~ 24</b>
<b>Hot Air Furnace, BNS series</b>	<b>25 ~ 26</b>

# BNG 15 ~ 35 Series One/Two Stage Gas Burners

## BNG 15~35 Technical and Performance Characteristics



1. Gas-fired burner.
2. One/Two-stage working.
3. Air-gas mixing at blast-pipe.
4. Ability to obtain optimal combustion values by regulating combustion air and blast-pipe.
5. Maintenance facilitated by the fact that the atomisation unit can be removed without having to remove the burner from the boiler.
6. Single stage manual flow adjustment.
7. Two stage Minimum and
8. One flange and one insulating seal for boiler fastening.
9. Combustion air intake with air flow adjustment device.
10. Sliding boiler coupling flange to adapt to head protrusion of the various types of boilers.
11. Monophase electric motor to run fan.
12. Flame presence check by ionisation electrode.
13. Electrical plant protection rating IP40.

Power Kw	Natural Gas Flow m <sup>3</sup> /h	Burner Model	Series Number	Power Supply	Motor Power Kw	Packing Size L x P x H mm	Weight Kg
50 ~ 150	5 ~ 16	BNG 15	101001	1N AC 50Hz 220V	0.18	580x465x350	16
80 ~ 280	8 ~ 28	BNG 28	101002	1N AC 50Hz 220V	0.37	850x530x395	28
90 ~ 360	9 ~ 36	BNG 35	101003	1N AC 50Hz 220V	0.37	850x530x395	28

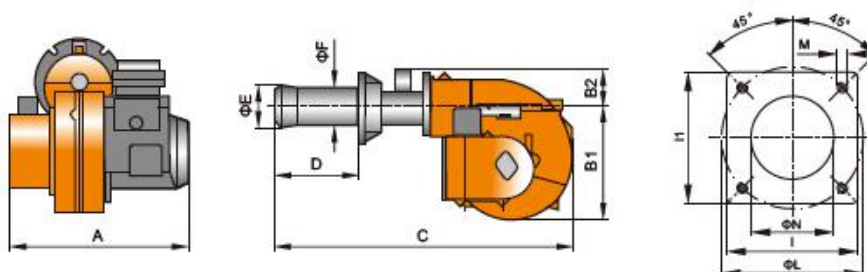

Burner Model	A mm	B1 mm	B2 mm	C mm	D mm	E mm	F mm	N mm	L mm	I mm	M mm
BNG 15	310	230	120	528	80~200	108	95	110	155	170	M12
BNG 28	422	263	102	800	120~280	135	114	140	170~210	185	M12
BNG 35	422	263	102	800	120~280	135	133	145	200~245	215	M12

# BNG 50 ~ 85 Series One/Two Stage Gas Burners

## BNG 50~85 Technical and Performance Characteristics



1. Gas-fired burner. maximum air flow regulation for first and
2. One/Two-stage working. second stage by means of electric servomotor
3. Air-gas mixing at blast-pipe. with pause closure of gate to prevent any heat
4. Ability to obtain optimal dispersion to flue.
5. Maintenance facilitated by the fact that the atomisation unit can be removed without having to remove the burner from the boiler.
6. Single stage manual flow adjustment.
7. Two stage Minimum and maximum air flow regulation for first and second stage by means of electric servomotor with pause closure of gate to prevent any heat dispersion to flue.
8. One flange and one insulating seal for boiler fastening.
9. Combustion air intake with air flow adjustment device.
10. Sliding boiler coupling flange to adapt to head protrusion of the various types of boilers.
11. Three-phase electric motor to run fan.
12. Flame presence check by ionisation electrode.
13. Electrical plant protection rating IP40.

Power Kw	Natural Gas Flow m <sup>3</sup> /h	Burner Model	Series Number	Power Supply	Motor Power Kw	Packing Size L x P x H mm	Weight Kg
170 ~ 600	17 ~ 60	BNG 50	101004	3N AC 50Hz 380V	0.55	1050x900x700	60
250 ~ 740	25 ~ 75	BNG 60	101005	3N AC 50Hz 380V	0.55	1050x900x700	60
280 ~ 850	28 ~ 86	BNG 85	101006	3N AC 50Hz 380V	1.5	1250x900x800	95

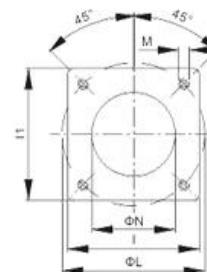
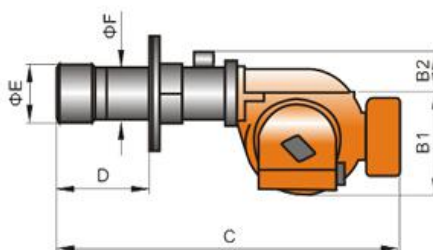

Burner Model	A mm	B1 mm	B2 mm	C mm	D mm	E mm	F mm	N mm	L mm	I mm	M mm
BNG 50	475	295	108	1063	150~350	155	133	160	200~245	215	M12
BNG 60	475	295	108	1063	150~350	155	133	160	200~245	215	M12
BNG 85	620	400	120	1330	240~460	230	159	215	233	290	M14

# BNG 85 ~ 250 Series Two Stage / Modulating Gas Burners

## BNG 85~250 Technical and Performance Characteristics



1. Gas-fired burner. closure of gate to prevent any heat dispersion
2. Two-stage sliding/modulating working. to flue.
3. Air-gas mixing at blast-pipe. 8. Sliding/modulating The servo motor which
4. Ability to obtain optimal combustion values by regulating combustion air and fuel and air.
5. The hinge connection, can be opened naturally. 9. One flange and one insulating seal for boiler fastening. 10. Combustion air intake with air flow adjustment device. 11. Sliding boiler coupling flange to adapt to head protrusion of the various types of boilers.
6. Maintenance facilitated by the fact that the atomisation unit can be removed without having to remove the burner from the boiler. 12. Three-phase electric motor to run fan.
7. Two stage Minimum and maximum air flow regulation for first and second stage by means of electric servomotor with pause 13. Flame presence check by ionisation electrode.
14. Electrical plant protection rating IP40.

Power Kw	Natural Gas Flow m <sup>3</sup> /h	Burner Model	Series Number	Power Supply	Motor Power Kw	Packing Size L x P x H mm	Weight Kg
280 ~ 850	28 ~ 86	BNG 85 P	101010	3N AC 50Hz 380V	1.5	1250x900x800	95
350 ~ 1200	35 ~ 120	BNG 120 P	101011	3N AC 50Hz 380V	1.5	1250x900x800	120
490 ~ 2000	50 ~ 200	BNG 210 P	101012	3N AC 50Hz 380V	3	1350x1000x800	180
500 ~ 2500	50 ~ 250	BNG 250 P	101013	3N AC 50Hz 380V	7.5	1620x1200x1000	215

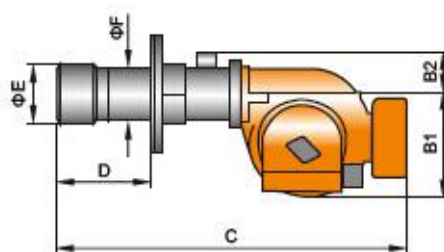

Burner Model	A mm	B1 mm	B2 mm	C mm	D mm	E mm	F mm	N mm	L mm	I mm	M mm
BNG 85 P	620	400	120	1330	240~460	230	159	215	233	290	M14
BNG 120 P	620	400	160	1370	240~460	270	194	220	276	320	M16
BNG 210 P	700	450	137	1600	300~550	320	219	230	339	400	M16
BNG 250 P	900	570	200	1850	300~600	320	219	230	339	400	M16

# BNG 300 ~ 600 Series Modulating Gas Burners

## BNG 300~600 Technical and Performance Characteristics



1. Gas-fired burner. closure of gate to prevent any heat dispersion
2. Two-stage sliding/modulating working. to flue.
3. Air-gas mixing at blast-pipe. 8. Sliding/modulating The servo motor which
4. Ability to obtain optimal combustion values by regulating combustion air and blast-pipe. fixed with a cam can adjust the consumption for fuel and air.
5. The hinge connection, can be opened naturally. 9. One flange and one insulating seal for boiler fastening. 10. Combustion air intake with air flow adjustment device. 11. Sliding boiler coupling flange to adapt to head protrusion of the various types of boilers.
6. Maintenance facilitated by the fact that the atomisation unit can be removed without having to remove the burner from the boiler. 12. Three-phase electric motor to run fan.
7. Two stage Minimum and maximum air flow regulation for first and second stage by means of electric servomotor with pause 13. Flame presence check by ionisation electrode.
14. Electrical plant protection rating IP40.

Burner Model	A mm	B1 mm	B2 mm	C mm	D mm	E mm	F mm	N mm	L mm	I mm	M mm
BNG 300 FC	900	570	260	1850	275~465	356	273	365	462~520	550	M16
BNG 350 FC	900	570	260	1850	275~465	356	273	365	462~520	550	M16
BNG 400 FC	900	570	260	1850	275~450	356	273	365	400~520	550	M18
BNG 600 FC	1000	590	330	1850	500	356	325	380	520	580	M20

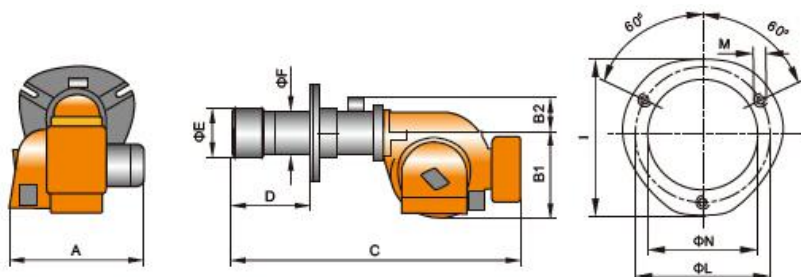

Power Kw	Natural Gas Flow m³/h	Burner Model	Series Number	Power Supply	Motor Power Kw	Packing Size L x P x H mm	Weight Kg
660 ~ 2980	65 ~ 300	BNG 300 FC	101014	3N AC 50Hz 380V	7.5	1620x1200x1000	220
920 ~ 3500	90 ~ 350	BNG 350 FC	101015	3N AC 50Hz 380V	7.5	1620x1200x1000	260
400 ~ 3950	40 ~ 400	BNG 400 FC	101016	3N AC 50Hz 380V	9	1620x1200x1000	320
800 ~ 5400	80 ~ 545	BNG 600 FC	101017	3N AC 50Hz 380V	15	1620x1200x1000	360

# BNL 14 ~ 35 Series One/Two Stage Light Oil Burners

## BNL 14~35 Technical and Performance Characteristics



1. Light oil burner.
2. Single/Two stage operation (on/off).
3. High pressure mechanical atomisation of fuel using nozzle .
4. Ability to obtain optimal combustion values by regulating combustion air and blast-pipe.
5. Maintenance facilitated by the fact that the atomisation unit can be removed without having to remove the burner from the boiler.
6. Single stage manual flow adjustment.
7. Two stage air flow regulation for first and second stage by means of hydraulic regulator.
8. One flange and one insulating seal for boiler fastening.
9. Combustion air intake with air flow adjustment device.
10. Sliding boiler coupling flange to adapt to head protrusion of the various types of boilers.
11. Sliding boiler coupling flange to adapt to head protrusion of the various types of boilers.
12. Monophase electric motor to run fan and pump.
13. Flame presence check by photo resistance.
14. Electrical plant protection rating Ip40.

Power Kw	Light Oil Flow Kg/H	Burner Model	Series Number	Power Supply	Motor Power Kw	Packing Size L x P x H mm	Weight Kg
89 ~ 172	7.5 ~ 14.5	BNL 14	101018	1N AC 50Hz 220V	0.18	580x465x350	16
154 ~ 308	13 ~ 26	BNL 26	101019	1N AC 50Hz 220V	0.37	850x530x395	25
178 ~ 391	15 ~ 33	BNL 35	101020	3N AC 50Hz 380V	0.37	850x530x395	25

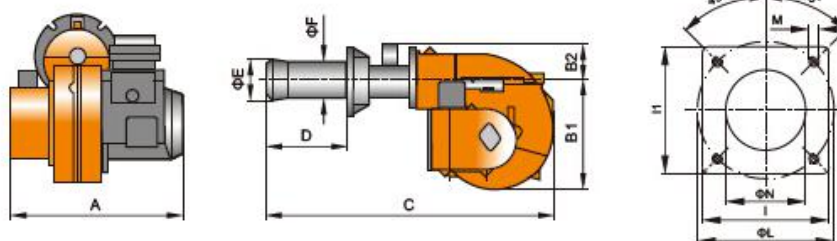

Burner Model	A mm	B mm	C mm	D mm	E mm	F mm	N mm	L mm	I mm	I1 mm	M mm
BNL 14	355	275	415	80-110	95	95	100	130-155	170	/	M12
BNL 26	460	350	610	105-200	135	114	145	170~210	185	185	M12
BNL 35	460	350	610	105-200	150	133	160	200-249	215	215	M12



# BNL 40 ~ 75 Series

## One/Two Stage Light Oil Burners

### BNL 40~75 Technical and Performance Characteristics



1. Light oil burner.
2. Two-stage operation (high/low flame).
3. High pressure mechanical atomisation of fuel using nozzle.
4. Ability to obtain optimal combustion values by regulating combustion air and blast-pipe.
5. The hinge connection, can be opened naturally.
6. Maintenance facilitated by the fact that the atomisation unit can be removed without having to remove the burner from the boiler.
7. Air flow regulation for first and second stage by means of hydraulic regulator.
8. One flange and one insulating seal for boiler fastening.
9. Combustion air intake with air flow adjustment device.
10. Sliding boiler coupling flange to adapt to head protrusion of the various types of boilers.
11. Sliding boiler coupling flange to adapt to head protrusion of the various types of boilers.
12. Three-phase electric motor to run fan and pump.
13. Flame presence check by photo resistance.
14. Electrical plant protection rating Ip40.

Power Kw	Light Oil Flow Kg/H	Burner Model	Series Number	Power Supply	Motor Power Kw	Packing Size L x P x H mm	Weight Kg
237 ~ 534	20 ~ 45	BNL 40 DSG	101021	3N AC 50Hz 380V	0.55	1050x900x700	50
332 ~ 652	28 ~ 55	BNL 55 DSG	101022	3N AC 50Hz 380V	0.55	1050x900x700	60
415 ~ 899	35 ~ 75	BNL 75 DSG	101023	3N AC 50Hz 380V	1.5	1250x900x800	90

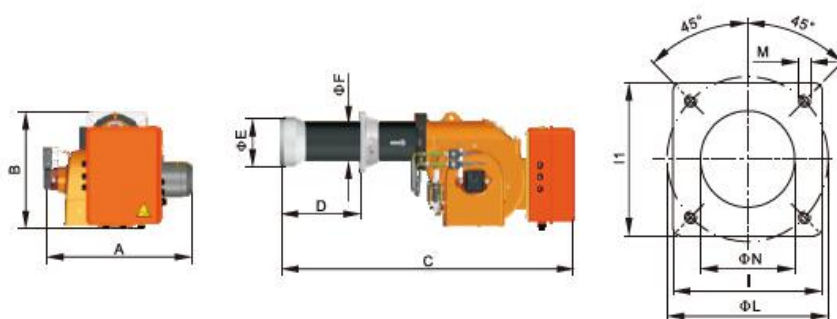

Burner Model	A mm	B mm	C mm	D mm	E mm	F mm	N mm	L mm	I mm	M mm
BNL 40 DSG	528	408	1046	120-305	170	133	175	200-245	215	M12
BNL 55 DSG	610	485	1215	120-400	170	133	175	200-245	215	M12
BNL 75 DSG	610	510	1250	170-400	205	159	215	233	290	M14

# BNL 100~180 Series Two-Stage/Modulating Light Oil Burners

## BNL 100~180 Technical and Performance Characteristics



1. Light oil burner.
2. Two-stage sliding/modulating working.
3. High pressure mechanical atomisation of fuel using nozzle.
4. Ability to obtain optimal combustion values by regulating combustion air and blast-pipe.
5. The hinge connection, can be opened naturally.
6. Maintenance facilitated by the fact that the atomisation unit can be removed without having to remove the burner from the boiler.
7. Two-stage Air flow regulation for first and second stage by means of hydraulic regulator. The burner is paused, close the throttle to reduce the loss of furnace heat.
8. Sliding/modulating The servo motor which fixed with a cam can adjust the consumption for fuel and air.
9. One flange and one insulating seal for boiler fastening.
10. Combustion air intake with air flow adjustment device.
11. Sliding boiler coupling flange to adapt to head protrusion of the various types of boilers.
12. Sliding boiler coupling flange to adapt to head protrusion of the various types of boilers.
13. Three-phase electric motor to run fan and pump.
14. Flame presence check by photo resistance.
15. Electrical plant protection rating Ip40.

Power Kw	Light Oil Flow Kg/H	Burner Model	Series Number	Power Supply	Motor Power Kw	Packing Size L x P x H mm	Weight Kg
533 ~ 1186	44 ~ 100	BNL 100 DSG	101024	3N AC 50Hz 380V	1.5	1250x900x800	90
474 ~ 1660	40 ~ 140	BNL 120 DSG	101025	3N AC 50Hz 380V	2.2	1250x1000x800	159
712 ~ 2135	60 ~ 180	BNL 180 DSG	101026	3N AC 50Hz 380V	3	1250x1200x800	190

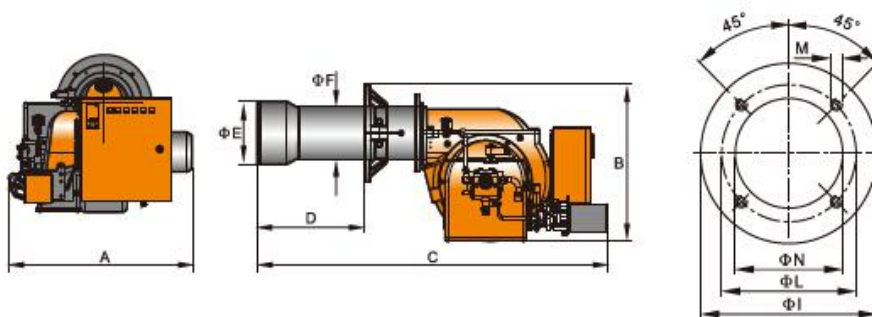

Burner Model	A mm	B mm	C mm	D mm	E mm	F mm	N mm	L mm	I mm	M mm
BNL 100 DSG	625	513	1270	170-400	230	194	240	276	320	M16
BNL 120 DSG	716	605	1350	170-400	230	194	240	276	320	M16
BNL 180 DSG	730	655	1480	245-450	260	219	270	339	400	M16

# BNL 250~600 Series Two-Stage/Modulating Light Oil Burners



## BNL 250~600 Technical and Performance Characteristics

1. Light oil burner. furnace heat.
2. Two-stage siding/modulating working. 8. Sliding/modulating The servo motor which fixed with a
3. High pressure mechanical atomisation of fuel using nozzle. cam can adjust the consumption for fuel and air.
4. Ability to obtain optimal combustion values by regulating combustion air and blast-pipe. device. 9. One flange and one insulating seal for boiler fastening.
5. The hinge connection, can be opened naturally. 10. Combustion air intake with air flow adjustment
6. Maintenance facilitated by the fact that the atomisation unit can be removed without having to remove the burner from the boiler. 11. Sliding boiler coupling flange to adapt to head protrusion of the various types of boilers.
7. Two-stage Air flow regulation for first and second stage by means of hydraulic regulator. The burner is paused, close the throttle to reduce the loss of 12. Sliding boiler coupling flange to adapt to head protrusion of the various types of boilers.
13. Three-phase electric motor to run fan and pump.
14. Flame presence check by photo resistance.
15. Electrical plant protection rating Ip40.

Power Kw	Light Oil Flow Kg/H	Burner Model	Series Number	Power Supply	Motor Power Kw	Packing Size L x P x H mm	Weight Kg
873 ~ 3186	73 ~ 268	BNL 250 FC	101027	3N AC 50Hz 380V	7.5	1620x1200x1000	260
1304 ~ 3854	110 ~ 325	BNL 300 FC	101028	3N AC 50Hz 380V	7.5	1620x1200x1000	300
1364 ~ 4151	115 ~ 350	BNL 350 FC	101029	3N AC 50Hz 380V	9	1620x1200x1000	310
1840 ~ 5522	155 ~ 465	BNL 600 FC	101030	3N AC 50Hz 380V	11	1620x1200x1000	330

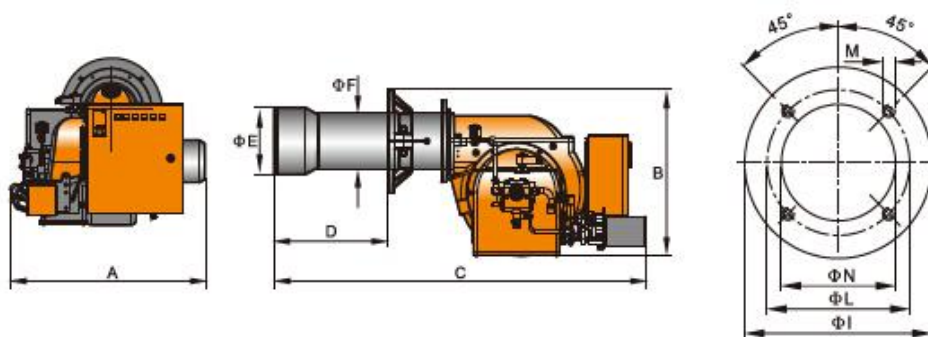

Burner Model	A mm	B mm	C mm	D mm	E mm	F mm	N mm	L mm	I mm	M mm
BNL 250 FC	970	770	1560	245-450	260	219	270	339	400	M16
BNL 300 FC	995	860	1830	240-600	356	273	380	462-520	550	M20
BNL 350 FC	995	860	1830	240-600	356	273	380	462-520	550	M20
BNL 600 FC	995	860	1830	500	365	325	380	520	580	M20

# BNH 10 ~ 60 Series Heavy Oil Burners(Air Atomizing)

## BNH 10~30 Technical and Performance Characteristics



1. Heavy oil burner.
2. Two-stage sliding/modulating working.
3. Air or steam to sprayer.
4. Ability to obtain optimal combustion values by regulating combustion air and blast-pipe.
5. The hinge connection, can be opened naturally.
6. Maintenance facilitated by the fact that the atomisation unit can be removed without having to remove the burner from the boiler.
7. The burner is paused, close the throttle to reduce the loss of furnace heat.
8. The servo motor which fixed with a cam can adjust the consumption for fuel and air.
9. With control valve and stop valve.
10. With the fuel pre-heater which installed with thermometer and adjustable temperature controller.
11. One flange and one insulating seal for boiler fastening.
12. Combustion air intake with air flow adjustment device.
13. Adjustable blast-pipe with stainless steel nozzle and deflector disk in steel.
14. Three-phase electric motor to run fan.
15. Flame presence check by photo resistance.
16. Electrical plant protection rating IP40.

Power Kw	Heavy Oil Flow Kg/H	Burner Model	Series Number	Power Supply	Motor Power Kw	Packing Size L x P x H mm	Weight Kg
340 ~ 1040	30 ~ 93	BNH 10 G	101044	3N 380V 50Hz	1.1	970x700x900	151
670 ~ 2050	60 ~ 183	BNH 20 G	101045	3N 380V 50Hz	3	1140x800x990	185
1220 ~ 3350	109 ~ 300	BNH 30 G	101046	3N 380V 50Hz	7.5	1620x1200x960	240

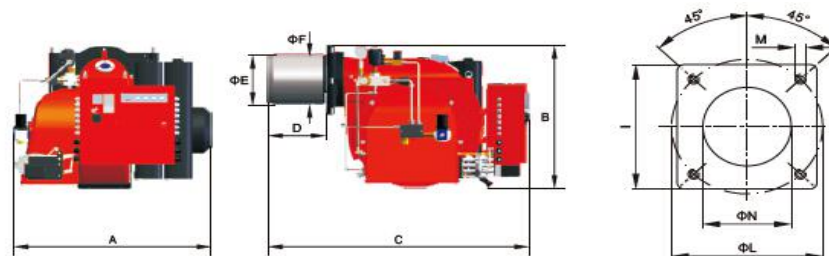

Burner Model	A mm	B mm	C mm	D mm	E mm	F mm	N mm	L mm	I mm	M mm
BNH 10 G	605	705	865	162	190	147	200	325	280	4-M12
BNH 20 G	712	780	1058	238	220	188	230	339	300	4-M16
BNH 30 G	940	935	1197	268	260	260	280	393	330	4-M16

# BNH 10 ~ 60 Series Heavy Oil Burners(Air Atomizing)

## BNH 40~60 Technical and Performance Characteristics



1. Heavy oil burner.
2. Two-stage sliding/modulating working.
3. Air or steam to sprayer.
4. Ability to obtain optimal combustion values by regulating combustion air and blast-pipe.
5. The hinge connection, can be opened naturally.
6. Maintenance facilitated by the fact that the atomisation unit can be removed without having to remove the burner from the boiler.
7. The burner is paused, close the throttle to reduce the loss of furnace heat.
8. The servo motor which fixed with a cam can adjust the consumption for fuel and air.
9. With control valve and stop valve.
10. With the fuel pre-heater which installed with thermometer and adjustable temperature controller.
11. One flange and one insulating seal for boiler fastening.
12. Combustion air intake with air flow adjustment device.
13. Adjustable blast-pipe with stainless steel nozzle and deflector disk in steel.
14. Three-phase electric motor to run fan.
15. Flame presence check by photo resistance.
16. Electrical plant protection rating IP40.

Power Kw	Heavy Oil Flow Kg/H	Burner Model	Series Number	Power Supply	Motor Power Kw	Packing Size L x P x H mm	Weight Kg
1280 ~ 3950	115 ~ 350	BNH 40 G	101047	3N 380V 50Hz	9	1620x1200x960	260
1840 ~ 5600	165 ~ 500	BNH 40 G	101048	3N 380V 50Hz	15	1620x1200x960	335

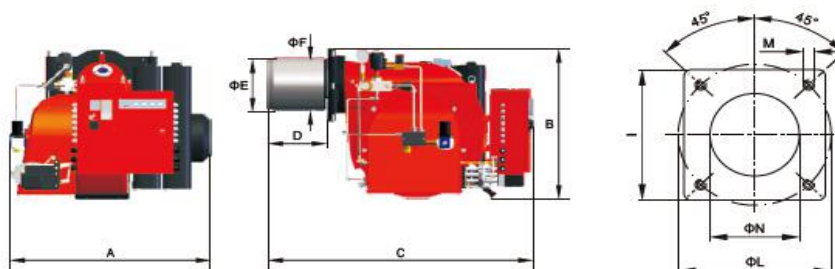

Burner Model	A mm	B mm	C mm	D mm	E mm	F mm	N mm	L mm	I mm	M mm
BNH 40 G	940	935	1240	276	264	264	275	330	380	4-M16
BNH 60 G	945	1044	1727	445	365	325	380	520	580	4-M16

# BNH 75 ~ 180 Series Heavy Oil Burners(Mechanical Atomizing)

## BNH 75~180 Technical and Performance Characteristics



1. Heavy oil burner.
2. Two-stage operation (high/low flame).
3. High pressure mechanical atomisation of fuel using nozzle.
4. Ability to obtain optimal combustion values by regulating combustion air and blast-pipe.
5. Maintenance facilitated by the fact that the atomisation unit can be removed without having to remove the burner from the boiler.
6. Minimum and maximum air flow regulation for first and second stage by means of electric servomotor with pause closure of gate to prevent any heat dispersion to flue.
7. With the fuel pre-heater which installed with thermometer and adjustable temperature controller.
8. One flange and one insulating seal for boiler fastening.
9. Combustion air intake with air flow adjustment device.
10. Adjustable blast-pipe with stainless steel nozzle and deflector disk in steel.
11. Three-phase electric motor to run fan and pump.
12. Flame presence check by photo resistance.
13. Electrical plant protection rating Ip40.

Power Kw	Heavy Oil Flow Kg/H	Burner Model	Series Number	Power Supply	Motor Power Kw	Packing Size L x P x H mm	Weight Kg
446 ~ 837	40 ~ 75	BNH 75 F	101049	3N 380V 50Hz	1.1	1450x830x815	108
558 ~ 1116	50 ~ 100	BNH 100 F	101050	3N 380V 50Hz	1.5	1450x830x815	116
669 ~ 1451	60 ~ 130	BNH 120 F	101051	3N 380V 50Hz	2.2	1450x830x815	170
725 ~ 2009	65 ~ 180	BNH 180 F	101052	3N 380V 50Hz	3	1450x830x815	195

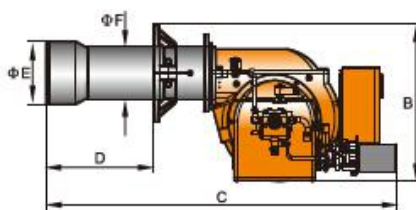
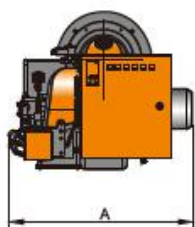

Burner Model	A mm	B mm	C mm	D mm	E mm	F mm	N mm	L mm	I mm	M mm
BNH 75 F	620	510	1200	170~400	205	159	215	233	290	4-M12
BNH 100 F	620	525	1250	180~400	230	194	240	276	320	4-M16
BNH 120 F	720	610	1340	185~400	230	194	240	276	320	4-M16
BNH 180 F	730	650	1420	200~535	260	219	270	339	400	4-M16

# BNH 250 ~ 600 Series Heavy Oil Burners(Mechanical)

## BNH 250~600 Technical and Performance Characteristics



1. Heavy oil burner.
2. Two-stage operation (high/low flame).
3. High pressure mechanical atomisation of fuel using nozzle.
4. Ability to obtain optimal combustion values by regulating combustion air and blast-pipe.
5. Maintenance facilitated by the fact that the atomisation unit can be removed without having to remove the burner from the boiler.
6. Minimum and maximum air flow regulation for first and second stage by means of electric servomotor with pause closure of gate to prevent any heat dispersion to flue.
7. With the fuel pre-heater which installed with thermometer and adjustable temperature controller.
8. One flange and one insulating seal for boiler fastening.
9. Combustion air intake with air flow adjustment device.
10. Adjustable blast-pipe with stainless steel nozzle and deflector disk in steel.
11. Three-phase electric motor to run fan and pump.
12. Flame presence check by photo resistance.
13. Electrical plant protection rating Ip40.

Power Kw	Heavy Oil Flow Kg/H	Burner Model	Series Number	Power Supply	Motor Power Kw	Packing Size L x P x H mm	Weight Kg
937 ~ 3170	80 ~ 280	BNH 250 F	101053	3N 380V 50Hz	7.5	1620x1200x960	255
1220 ~ 3460	109 ~ 310	BNH 300 F	101054	3N 380V 50Hz	7.5	1620x1200x960	295
1284 ~ 3907	115 ~ 350	BNH 350 F	101055	3N 380V 50Hz	9	1620x1200x960	305
1840 ~ 5500	165 ~ 490	BNH 600 F	101056	3N 380V 50Hz	15	1620x1200x960	325

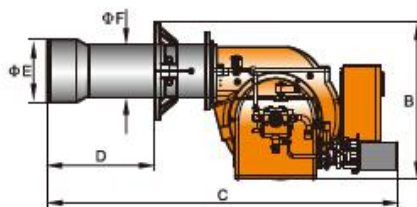

Burner Model	A mm	B mm	C mm	D mm	E mm	F mm	N mm	L mm	I mm	M mm
BNH 250 F	948	780	1536	235~590	260	219	270	339	400	4-M16
BNH 300 F	948	860	1820	245~605	356	273	380	462~520	550	3-M20
BNH 350 F	948	860	1820	245~605	356	275	365	462~520	550	3-M20
BNH 600 F	985	860	1820	500	365	325	380	520	580	6-M20

# BNGL 15 ~ 35 Series Dual Fuel Burners(Light Oil & Gas)

## BNGL 15~35 Technical and Performance Characteristics



1. Alternate methane gas/light oil burner.
2. Single stage operation (on/off).
3. Air-gas mixing at blast-pipe and high pressure mechanical atomisation of fuel using nozzle.
4. Ability to obtain optimal combustion values by regulating combustion air and blast-pipe.
5. Maintenance facilitated by the fact that the mixing unit and the atomisation unit can be removed without having to remove the burner from the boiler.
6. Manual flow adjustment.
7. Equipped with one flange and one insulating seal for boiler fastening.
8. Combustion air intake with air flow adjustment device.
9. Sliding boiler coupling flange to adapt to head protrusion of the various types of boilers.
10. A Monophase electric motor to run fan and another to run the pump.
11. Flame presence check by photo resistance and ionisation electrode.
12. Electrical plant protection rating IP40.

Power Kw	Natural Gas Flow m³/h	Burner Model	Series Number	Power Supply	Motor Power Kw	Packing Size L x P x H mm	Weight Kg
50 ~ 150	5 ~ 16	BNGL 15	101031	1N 220V 50Hz	0.15+0.11	650x520x360	25
100 ~ 300	10 ~ 30	BNGL 28	101032	1N 220V 50Hz	0.37+0.11	870x620x440	42
130 ~ 340	13 ~ 35	BNGL 35	101033	1N 220V 50Hz	0.37+0.15	870x620x440	45

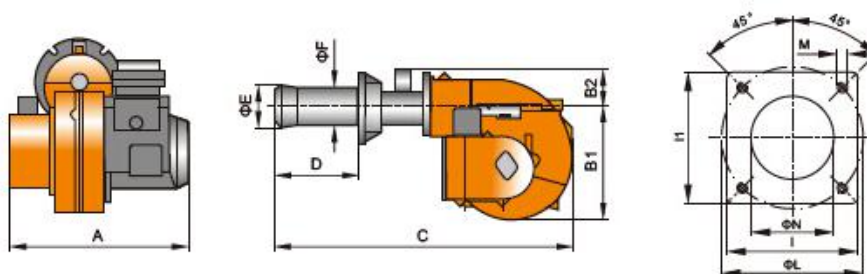

Burner Model	A mm	B1 mm	B2 mm	C mm	D mm	E mm	F mm	N mm	L mm	I mm	M mm
BNGL 15	475	203	89	595	110~160	108	95	110	130~155	170	M12
BNGL 28	537	253	93	807	120~280	135	114	140	170~210	185	M12
BNGL 35	537	253	105	800	105~258	155	133	160	200~244	215	4-M12



# BNGL 35 ~ 85 Series Dual Fuel Burners(Light Oil & Gas)

## BNGL 35~85 Technical and Performance Characteristics



1. Alternate methane gas/light oil burner. the mixing unit and the atomisation unit can be removed without having to remove the burner from the boiler.
2. Two-stage operation (high/low flame).
3. Air-gas mixing at blast-pipe and high pressure mechanical atomisation of fuel using nozzle.
4. Ability to obtain optimal combustion values by regulating combustion air and blast-pipe.
5. Maintenance facilitated by the fact that the mixing unit and the atomisation unit can be removed without having to remove the burner from the boiler.
6. Maintenance facilitated by the fact that
7. Equipped with one flange and one insulating seal for boiler fastening.
8. Combustion air intake with air flow adjustment device.
9. Sliding boiler coupling flange to adapt to head protrusion of the various types of boilers.
10. Sliding boiler coupling flange to adapt to head protrusion of the various types of boilers.
11. UV ultraviolet phototube detects flame.
12. Electrical plant protection rating IP40.

Power Kw	Natural Gas Flow m³/h	Burner Model	Series Number	Power Supply	Motor Power Kw	Packing Size L x P x H mm	Weight Kg
130 ~ 340	13 ~ 35	BNGL 35 P	101034	1N 220V 50Hz	0.37+0.15	870x620x440	56
200 ~ 600	20 ~ 60	BNGL 50 P	101035	3N 380V 50Hz	0.37+0.15	860x680x600	95
280 ~ 850	28 ~ 86	BNGL 85 P	101036	3N 380V 50Hz	1.1+0.37	1050x900x710	132

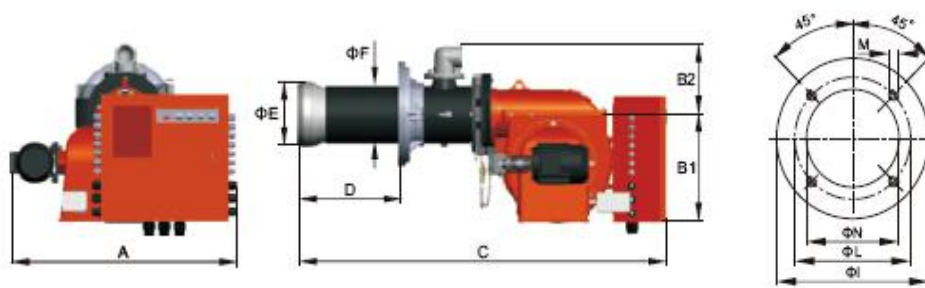

Burner Model	A mm	B1 mm	B2 mm	C mm	D mm	E mm	F mm	N mm	L mm	I mm	M mm
BNGL 35 P	537	253	105	780	140~258	155	133	160	200~244	215	4-M12
BNGL 50 P	595	300	197	1085	140~315	160	159	170	233	290	4-M12
BNGL 85 P	800	360	247	1300	175~360	200	194	210	276	320	4-M16

# BNGL 120~250 Series Dual Fuel Burners(Light Oil & Gas)

## BNGL 120~250 Technical and Performance Characteristics



1. Alternate methane gas/light oil burner.
2. Two-stage sliding/modulating working.
3. Air-gas mixing at blast-pipe and high pressure mechanical atomisation of fuel using nozzle.
4. Ability to obtain optimal combustion values by regulating combustion air and blast-pipe.
5. The hinge connection, can be opened naturally.
6. Maintenance facilitated by the fact that the mixing unit and the atomisation unit can be removed without having to remove the burner from the boiler.
7. Two-stage Minimum and maximum air flow regulation for first and second stage by means of electric servomotor with pause closure of gate to prevent any heat dispersion to flue.
8. Sliding/modulating The servo motor which fixed with a cam can adjust the consumption for fuel and air.
9. Equipped with one flange and one insulating seal for boiler fastening.
10. Combustion air intake with air flow adjustment device.
11. Sliding boiler coupling flange to adapt to head protrusion of the various types of boilers.
12. Adjustable blast-pipe with stainless steel nozzle and deflector disk in steel.
13. A three-phase electric motor to run fan and another to run the pump.
14. UV ultraviolet phototube detects flame.
15. Electrical plant protection rating Ip40.

Power Kw	Natural Gas Flow m <sup>3</sup> /h	Burner Model	Series Number	Power Supply	Motor Power Kw	Packing Size L x P x H mm	Weight Kg
650 ~ 1365	65 ~ 138	BNGL 120 P	101037	3N 380V 50Hz	2.2+0.37	1250x1150x780	170
700 ~ 2100	70 ~ 210	BNGL 210 P	101038	3N 380V 50Hz	3+0.55	1250x1150x780	221
1130 ~ 3380	114 ~ 340	BNGL 250 P	101039	3N 380V 50Hz	7.5+0.75	1620x1200x960	310

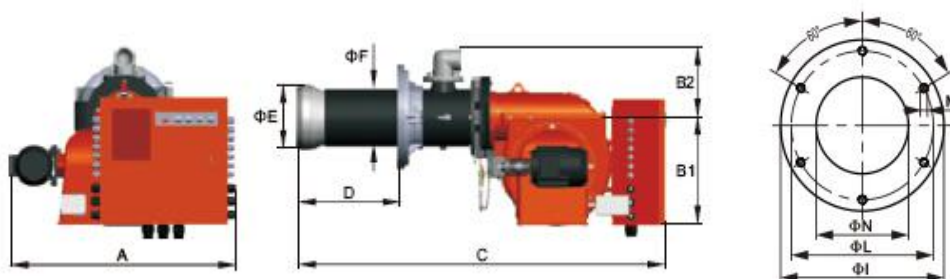

Burner Model	A mm	B1 mm	B2 mm	C mm	D mm	E mm	F mm	N mm	L mm	I mm	M mm
BNGL 120 P	875	440	230	1500	195~540	200	194	210	276	370	4-M16
BNGL 210 P	870	435	230	1735	195~579	250	245	260	390-410	460	6-M20
BNGL 250 P	1050	575	280	1800	505	290	299	310	462~520	560	6-M20

# BNGL 350~600 Series Dual Fuel Burners(Light Oil & Gas)

## BNGL 350~600 Technical and Performance Characteristics



1. Alternate methane gas/light oil burner.
2. Two-stage sliding/modulating working.
3. Air-gas mixing at blast-pipe and high pressure mechanical atomisation of fuel using nozzle.
4. Ability to obtain optimal combustion values by regulating combustion air and blast-pipe.
5. The hinge connection, can be opened naturally.
6. Maintenance facilitated by the fact that the mixing unit and the atomisation unit can be removed without having to remove the burner from the boiler.
7. Two-stage Minimum and maximum air flow regulation for first and second stage by means of electric servomotor with pause closure of gate to prevent any heat dispersion to flue.
8. Sliding/modulating The servo motor which fixed with a cam can adjust the consumption for fuel and air.
9. Equipped with one flange and one insulating seal for boiler fastening.
10. Combustion air intake with air flow adjustment device.
11. Sliding boiler coupling flange to adapt to head protrusion of the various types of boilers.
12. Adjustable blast-pipe with stainless steel nozzle and deflector disk in steel.
13. A three-phase electric motor to run fan and another to run the pump.
14. UV ultraviolet phototube detects flame.
15. Electrical plant protection rating Ip40.

Power Kw	Natural Gas Flow m <sup>3</sup> /h	Burner Model	Series Number	Power Supply	Motor Power Kw	Packing Size L x P x H mm	Weight Kg
1300 ~ 3880	130 ~ 390	BNGL 350 FC	101040	3N 380V 50Hz	9+0.75	1620x1200x960	360
1300 ~ 3880	130 ~ 390	BNGL 400 FC	101041	3N 380V 50Hz	9+0.75	1620x1200x960	310
1850 ~ 5500	187 ~ 556	BNGL 600 FC	101042	3N 380V 50Hz	15+2.2	1620x1200x960	335

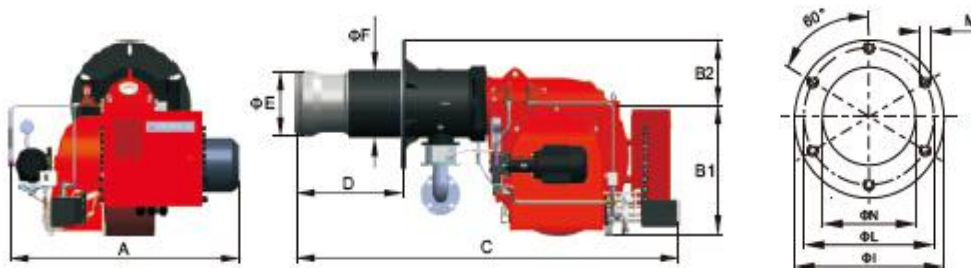

Burner Model	A mm	B1 mm	B2 mm	C mm	D mm	E mm	F mm	N mm	L mm	I mm	M mm
BNGL 350 FC	1150	575	280	1800	505	300	299	320	462~520	560	6-M20
BNGL 400 FC	1115	570	280	1785	350~495	300	299	320	462~520	550	6-M20
BNGL 600 FC	1130	570	290	1755	445	365	325	380	520	580	6-M20

# BNGH 120~250 Series Dual Fuel Burners(Heavy Oil & Gas)

## BNGH 120~250 Technical and Performance Characteristics



1. Alternate methane gas/heavy oil burner.
2. Two-stage sliding/modulating working.
3. Air-gas mixing at blast-pipe and high pressure mechanical atomisation of fuel using nozzle.
4. Ability to obtain optimal combustion values by regulating combustion air and blast-pipe.
5. The hinge connection, can be opened naturally.
6. Maintenance facilitated by the fact that the mixing unit and the atomisation unit can be removed without having to remove the burner from the boiler.
7. Minimum and maximum air flow regulation for first and second stage by means of electric servomotor with pause closure of gate to prevent any heat dispersion to flue.
8. The servo motor which fixed with a cam can adjust the consumption for fuel and air.
9. Equipped with one flange and one insulating seal for boiler fastening.
10. Combustion air intake with air flow adjustment device.
11. Sliding boiler coupling flange to adapt to head protrusion of the various types of boilers.
12. Adjustable blast-pipe with stainless steel nozzle and deflector disk in steel.
13. Three-phase electric motor to run fan and another to run the pump.
14. UV ultraviolet phototube detects flame.
15. Electrical plant protection rating Ip40.

Power Kw	Natural Gas Flow m <sup>3</sup> /h	Burner Model	Series Number	Power Supply	Motor Power Kw	Packing Size L x P x H mm	Weight Kg
650 ~ 1365	24 ~ 120	BNGH 120 P	101043	3N 380V 50Hz	2.2	1250x1150x780	170
700 ~ 2100	40 ~ 210	BNGH 210 P	101044	3N 380V 50Hz	3	1450x830x815	240
1130 ~ 3380	87 ~ 318	BNGH 250 P	101045	3N 380V 50Hz	7.5	1620x1200x960	300

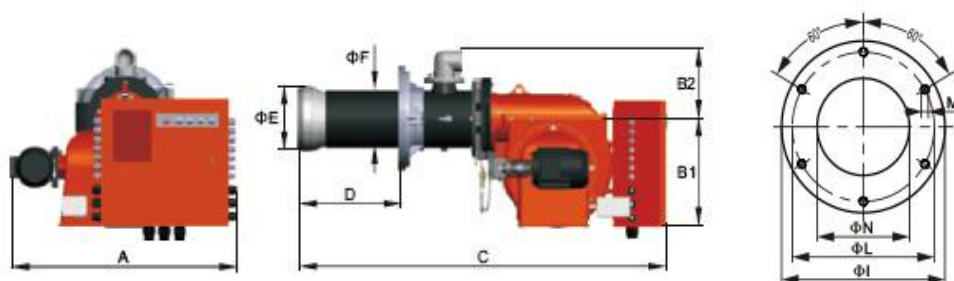

Burner Model	A mm	B1 mm	B2 mm	C mm	D mm	E mm	F mm	N mm	L mm	I mm	M mm
BNGH 120 P	875	440	230	1500	195~540	200	194	210	276	370	4-M16
BNGH 210 P	880	445	230	1787	370~579	250	245	260	400	460	6-M20
BNGH 250 P	1050	570	280	1785	350~495	290	299	310	462~520	460	6-M20

# BNGH 400~600 Series Dual Fuel Burners(Heavy Oil & Gas)

## BNGH 400~600 Technical and Performance Characteristics



1. Alternate methane gas/heavy oil burner. prevent any heat dispersion to flue.
2. Two-stage sliding/modulating working. 8. The servo motor which fixed with a cam can adjust the consumption for fuel and air.
3. Air-gas mixing at blast-pipe and high pressure mechanical atomisation of fuel using nozzle. 9. Equipped with one flange and one insulating seal for boiler fastening.
4. Ability to obtain optimal combustion values by regulating combustion air and blast-pipe. 14. Combustion air intake with air flow adjustment device.
5. The hinge connection, can be opened naturally. 15. Sliding boiler coupling flange to adapt to head protrusion of the various types of boilers.
6. Maintenance facilitated by the fact that the mixing unit and the atomisation unit can be removed without having to remove the burner from the boiler. 16. Adjustable blast-pipe with stainless steel nozzle and deflector disk in steel.
7. Minimum and maximum air flow regulation for first and second stage by means of electric servomotor with pause closure of gate to 17. Three-phase electric motor to run fan and another to run the pump.
14. UV ultraviolet phototube detects flame.
15. Electrical plant protection rating Ip40.

Power Kw	Natural Gas Flow m³/h	Burner Model	Series Number	Power Supply	Motor Power Kw	Packing Size L x P x H mm	Weight Kg
1300 ~ 3880	89 ~ 445	BNGH 400 FC	101046	3N 380V 50Hz	7.5	1620x1200x960	320
1850 ~ 5500	184 ~ 550	BNGH 600 FC	101047	3N 380V 50Hz	15	1620x1200x960	370

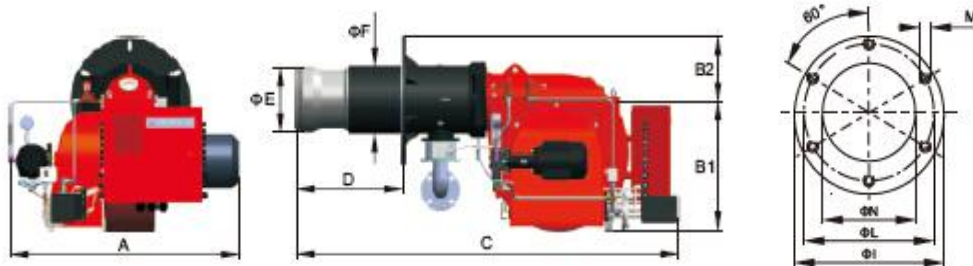

Burner Model	A mm	B1 mm	B2 mm	C mm	D mm	E mm	F mm	N mm	L mm	I mm	M mm
BNGH 400 FC	1115	570	280	1785	350~495	300	299	320	462~520	550	6-M20
BNGH 600 FC	1130	570	290	1755	445	365	325	380	520	580	6-M20

## Low NOx Combustion Technology

Fuel gas and oil, the nitrogen oxides (NOx) produced during the combustion process are mainly nitric oxide (NO) and nitrogen dioxide (NO<sub>2</sub>), collectively referred to as NOx. The nitrogen oxides discharged into the air are harmful to the environment and human body because of the easy formation of acid rain and acid mist, so they have increasingly clear requirements for their emissions. During the combustion process, the amount of NO generated and emitted is closely related to the combustion method, fuel characteristics, reaction zone, flue gas composition, and combustion conditions. The characteristics of coal types, combustion temperature and excess air coefficient "a" are the main influencing factors.

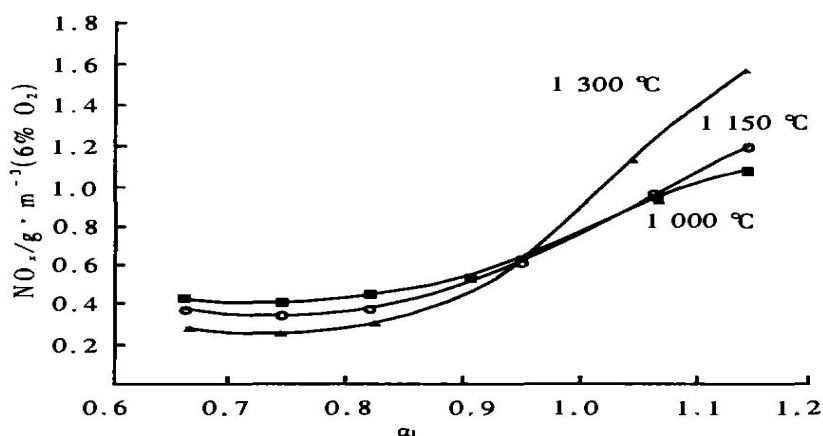

At different temperatures, The relationship between NOx mass concentration and "a" .

The main technical principle of BNTET's low NOx burners, is to achieve the effect of air classification, combustion classification or flue gas recirculation method in the fire zone of the burner, through the specially designed burner structure and changing the ratio of wind and fuel passing through the burner .

While ensuring combustion, it effectively suppresses the formation of nitrogen oxides. The primary air in the fuel pipeline is divided into two horizontally dense and light airflows. One of them is a relatively high fuel concentration fuel flow, which contains most of the fuel; the other is a relatively low fuel concentration fuel flow, air Mainly.

Using BNTET's low NOx burner, you only need to replace the original burner with a low NOx burner. No changes are required to the combustion system and boiler/furnace structure. Therefore, it is the easiest and most economical technical measure to reduce NOx emissions on the original furnace.

### Fuel Oil & Gas Burner Standards And Pollutant Emission Requirements

mg/Nm<sup>3</sup>

Classification	Gas			Oil	
	Nitrogen Oxides (NOx)		Carbon Monoxide (CO)	Nitrogen Oxide (NOx)	Carbon Monoxide (CO)
	Natural Gas	Liquefied Petroleum Gas			
Ordinary Burner	≤120	≤180	≤100	≤185	≤110
Low NOx Burner	≤80	≤140		≤120	≤60

# Asphalt Mixing Plant Burner BNB Series

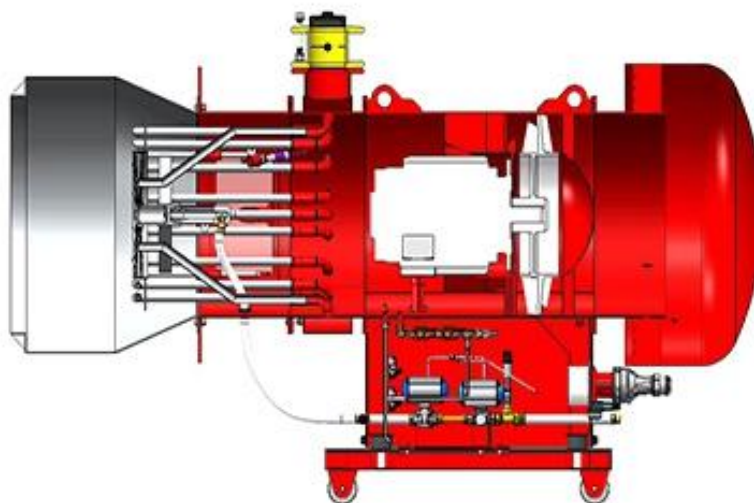

## Special Burner for Asphalt Mixing Plant

Supporting Asphalt Mixing Machine	1000	1300	1500	2000	3000	4000	5000
Burner Model	BNB-1000	BNB-1300	BNB-1500	BNB-2000	BNB-3000	BNB-4000	BNB-5000
Output Power (Kw)	6410	8390	9680	12840	19260	25500	31620
Output Power (Mcal)	5520	7220	8330	11050	16570	21930	27200
Pump Pressure (MPa)	1.2	1.2	1.2	1.2	1.2	1.2	1.2
Light Oil Consumption (Kg/H)	540	710	810	1080	1620	2150	2660
Heavy Oil Consumption (Kg/H)	570	750	860	1150	1720	2280	2830
Gas Consumption (m³/H)	650	850	980	1300	1950	2580	3200
Air Pressure (Kpa)	15~25	15~25	15~25	15~25	15~25	15~25	15~25
Gas Pipeline	65A	80A	80A	100A	150A	150A	150A
Blower							
Flow Rate (m³/Min)	170	190	260	340	510	680	850
Total Pressure (mmAg)	250						
Motor Power (kw)	18.5	18.5	22	30	45	55	75

# Rotary Kiln Burner BNRK Series



## Four Channel Burner

Single burner adaptation: 500 ~ 10000T/D production line

Applicable fuel:

- Pulverized coal, semi-coke.
- Natural gas, liquefied gas, coal gas, light hydrocarbon gas, etc.
- Light oil, heavy oil, residual oil, mixed oil

Mainly used in:

Cement kilns, pellet kilns, lime kilns, lithium kilns, magnesium oxide kilns, alumina kilns, chromium salt kilns, ore dressing kilns and other types of kilns for building materials, metallurgy, chemical industry, electric power and other industries.

According to the technological requirements, it can be designed as two-channel, three-channel, four-channel and five-channel burners.



## Three Channel Burner

Single burner adaptation: 500 ~ 10000T/D production line

Applicable fuel:

- Pulverized coal, semi-coke.
- Natural gas, liquefied gas, coal gas, light hydrocarbon gas, etc.
- Light oil, heavy oil, residual oil, mixed oil

Mainly used in:

Cement kilns, pellet kilns, lime kilns, lithium kilns, magnesium oxide kilns, alumina kilns, chromium salt kilns, ore dressing kilns and other types of kilns for building materials, metallurgy, chemical industry, electric power and other industries.

According to the technological requirements, it can be designed as two-channel, three-channel, four-channel and five-channel burners.



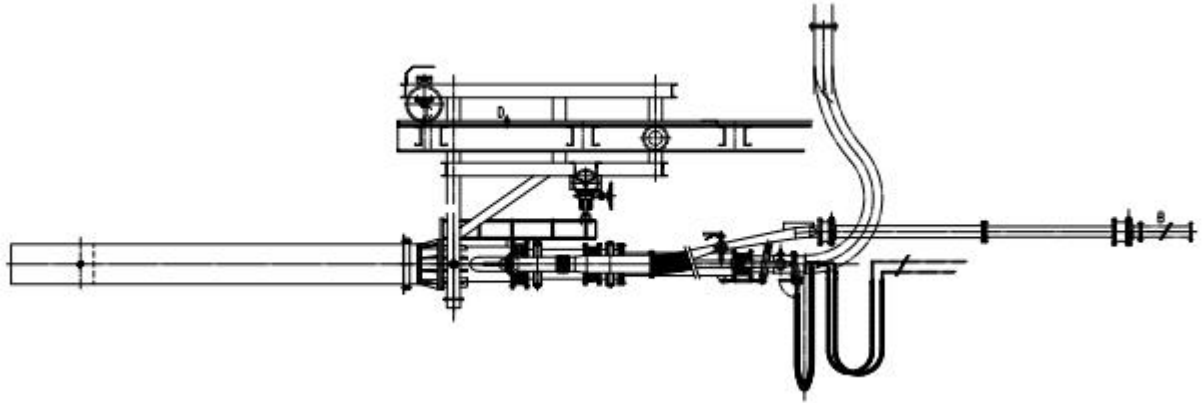

**Kiln Burner BNRK Series -- Model and Specification**

No.	Model	Specification	Heat Power Mcal	Heat Power (Mw/h)	Coal Flow (T/h)	Gas Flow (m³/h)	Oil Flow (Kg/h)	Regulation Ratio
20009	BNRK 500	500T/D	5000-15000	6-17	1-3	588-1765	490-1471	1:10
20010	BNRK 1200	1200 T/D	15000-25000	17-29	3-5	1765-2941	1471-2451	1:10
20011	BNRK 2000	2000 T/D	20000-30000	23-35	4-6	2353-3529	1961-2941	1:10
20012	BNRK 2500	2500 T/D	25000-40000	29-47	5-8	2941-4706	2451-3922	1:10
20013	BNRK 3000	3000 T/D	30000-45000	35-52	6-9	3529-5294	2941-4412	1:10
20014	BNRK 3200	3200 T/D	30000-45000	35-52	6-9	3529-5294	2941-4412	1:10
20015	BNRK 4000	4000 T/D	40000-60000	47-70	8-12	4706-7059	3922-5882	1:10
20016	BNRK 4500	4500 T/D	45000-75000	52-87	9-15	5294-8824	4412-7353	1:10
20017	BNRK 5000	5000 T/D	50000-90000	58-105	10-18	5882-10588	4902-8824	1:10
20018	BNRK 6000	6000 T/D	50000-100000	58-116	10-20	5882-11765	4902-9804	1:10
20019	BNRK 7000	7000 T/D	60000-120000	70-140	12-24	7059-14118	5882-11765	1:10
20020	BNRK 8000	8000 T/D	70000-140000	81-163	14-28	8235-16471	6863-13725	1:10
20021	BNRK 10000	10000 T/D	90000-150000	105-174	18-30	10588-17647	8824-14706	1:10

# Hot Air Furnace BNS Series



## Horizontal Hot Air Furnace

Single hot air furnace adaptation: 50 ~ 25000KW burner

Applicable fuel:

- Natural gas, liquefied gas, coal gas, light hydrocarbon gas, etc.
- Light oil, heavy oil, residual oil, mixed oil.
- Pulverized coal, coal, etc.

Mainly used in:

Preparation and drying of chemicals, chemical products and pharmaceuticals in the chemical and pharmaceutical industries; Baking paints, powder spray curing in the coating industry, etc.

Textile printing and dyeing and non-woven fabric industry; foundry industry, molding sand and sand core drying; abrasive tools, abrasive industry; drying in building materials industry.

Agricultural products, feed and food processing and baking; heating engineering; industrial plant and civil building heating; welding materials industry, welding electrodes, flux drying; insulation materials, fiberglass industry.



## Chain Type Hot Air Furnace

Single hot air furnace adaptation: 50 ~ 25000KW burner

Applicable fuel:

- Natural gas, liquefied gas, coal gas, light hydrocarbon gas, etc.
- Light oil, heavy oil, residual oil, mixed oil.
- Coal, etc.

Mainly used in:

Preparation and drying of chemicals, chemical products and pharmaceuticals in the chemical and pharmaceutical industries; Baking paints, powder spray curing in the coating industry, etc.

Textile printing and dyeing and non-woven fabric industry; foundry industry, molding sand and sand core drying; abrasive tools, abrasive industry; drying in building materials industry.

Agricultural products, feed and food processing and baking; heating engineering; industrial plant and civil building heating; welding materials industry, welding electrodes, flux drying; insulation materials, fiberglass industry.

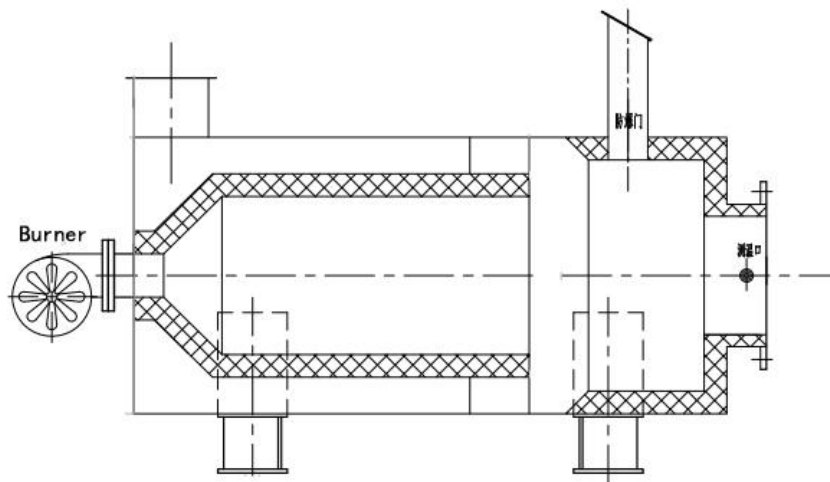

**Hot Air Furnace BNS Series -- Model and Specification**

No.	Model	Heat Power	Heat Power	Natural Gas Flow	Oversize	Weight Ton
		Mcal	(Kw/h)	m <sup>3</sup> /h	ø x L m	
30015	BNS50-10	200 ~ 600	230 ~ 698	24 ~ 71	ø1.2 x 2.5	2.6
30016	BNS50-15	250 ~ 850	320 ~ 988	33 ~ 100	ø1.2 x 3.0	3.1
30017	BNS50-20	300 ~ 1000	380 ~ 1163	39 ~ 118	ø1.2 x 3.2	3.2
30018	BNS50-25	400 ~ 1300	500 ~ 1512	51 ~ 153	ø1.3 x 2.5	3.2
30020	BNS50-30	500 ~ 1500	580 ~ 1744	59 ~ 176	ø1.3 x 3.0	4
30021	BNS60-10	400 ~ 2000	460 ~ 2326	47 ~ 235	ø1.3 x 4.0	4.5
30023	BNS60-15	500 ~ 2500	580 ~ 2907	59 ~ 294	ø1.4 x 3.5	4.5
30022	BNS60-20	600 ~ 3100	720 ~ 3605	73 ~ 365	ø1.4 x 5.5	6
30024	BNS60-25	650 ~ 3300	760 ~ 3837	78 ~ 388	ø1.5 x 3.5	6
30025	BNS60-30	450 ~ 4500	520 ~ 5233	53 ~ 529	ø1.5 x 5.0	7
30026	BNS70-20	650 ~ 6500	750 ~ 7558	76 ~ 765	ø1.6 x 4.2	7
30027	BNS70-25	850 ~ 8500	980 ~ 9884	100 ~ 1000	ø1.6 x 5.5	7.5
30028	BNS70-30	1100 ~ 11000	1270 ~ 12791	129 ~ 1294	ø1.6 x 6.0	8
30029	BNS70-35	1200 ~ 12000	1390 ~ 13953	141 ~ 1412	ø1.6 x 5.5	8.5
30030	BNS80-30	1300 ~ 13000	1510 ~ 15116	153 ~ 1529	ø1.8 x 5.5	9
30031	BNS90-10	1600 ~ 16000	1860 ~ 18605	188 ~ 1882	ø2.0 x 6.0	10
30032	BNS90-30	2200 ~ 22000	2550 ~ 25581	259 ~ 2588	ø2.2 x 6.0	12



---

**ZHENGZHOU BONA HEAT ENERGY EQUIPMENT CO., LTD.**

Website: [www.bntet-burner.com](http://www.bntet-burner.com)

Cell Phone: 0086 135 2304 0276

WhatsApp/WeChat ID: 0086 135 2304 0276

Tel: 0086-371-69812176 / 135 2304 0276

Factory Add.: Xinhua Road, Xinmi City, Zhengzhou City, Henan Province, China.