

BNTET[®]

Asphalt Mixing Plant Burners



ABOUT BNTET®



Zhengzhou Bona Heat Energy Equipment Co., Ltd is an innovative technology enterprise, which is focusing on the production, R & D and technical consulting services of burners, burner accessories, hot air furnace, and boiler related products.

Zhengzhou Bona Heat Energy Equipment Co., Ltd upholds the development and innovation consciousness, produces products with high-performance combustion technology.

Main Products:

Gas Burner;

Oil Burner(Diesel/Light Oil Burner, Heavy Oil Burner);

Dual Fuel Burner(Diesel/Light Oil or Gas, Heavy Oil or Gas);

Multi Fuel Burner;

Low NOx Burner;

Coal Burner;

Rotary Kiln Burner;

Asphalt Mixing Plant Burner;

Hot Air Furnace, etc.

Applicable Industries:

1. Cement and Mining: rotary kiln equipment, drying application.
2. Energy: boiler equipment, hot air furnace / hot blast stove.
3. Metal: steel, aluminum, copper, forging and heat treatment equipment.
4. Petroleum and Natural Gas: petrochemical furnaces, oil refinery, oil and gas plant process equipment (tracer, industrial burner).
5. Asphalt Mixing Plant, Incinerator, Foundry Machinery, Industrial Stoves, and other thermal machinery supporting equipment.

Main Features of BNB Series Burners

◎BNB series burners have features of high intelligence, high stability, high safety, long life; and excellent performance of low failure rate, low energy consumption, low pollution, low maintenance, etc.

◎BNB series burner adopts advanced PLC intelligent control system, electronic modulating/proportional adjustment operation, touch screen operation interface, which makes the operation status and setting parameters of the burner more intuitive and user-friendly.

◎Designed for the asphalt mixing plant, the burner body and the fan are integrated structure, the structure is more compact, the installation is simple, and the flame is strong and powerful.

◎Heavy/residue oil, Diesel, gas, and gas/oil dual fuel burners can use different types of heavy oil, fuel oil, and natural gas.

◎Oil type adopts bubble atomizing nozzle, good atomization effect, enables the fuel to burn fully. The fuel pressure is low, the fuel nozzle is not easy to wear, and the service life is extended.

◎The speed of the oil pump is controlled by frequency conversion. Under low speed and low pressure, the service life of the oil pump is greatly improved.

◎Precise oil temperature control. The oil circuit system adopts heat-conducting oil for heating, and the heat-conducting oil pipeline is equipped with intelligent flow control valve. According to the temperature of the fuel oil, to control the flow of the heat-conducting oil, and control the temperature of the fuel oil.

◎When something goes wrong, while the sound and light alarms, the operation screen will display the cause of the fault, and the information of the troubleshooting method. So that the user can easily and efficiently troubleshoot and resume operation.

BNB Series Asphalt Mixing Plant Burners

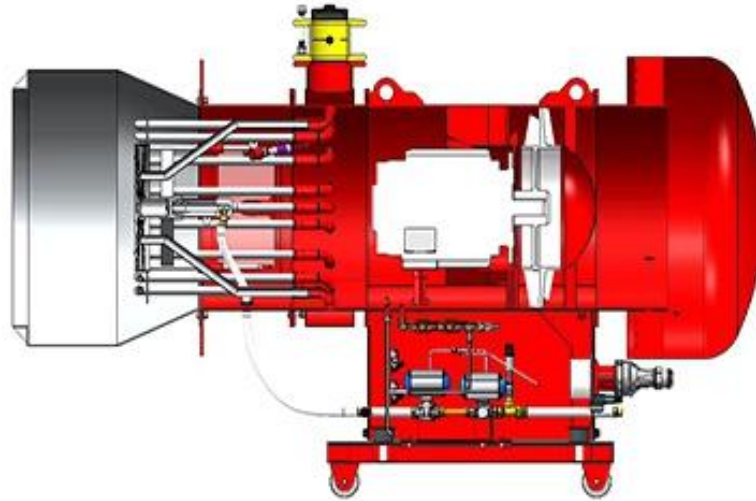

Special Burner for Asphalt Mixing Plant

Supporting Asphalt Mixing Machine	500	1000	2000	3000	4000	5000
Burner Model	BNB-500	BNB-1000	BNB-2000	BNB-3000	BNB-4000	BNB-5000
Supporting Asphalt Mixing Plant (Ton/Hour)	30-40	70-80	140-150	210-220	290-300	350-360
Output Power (kW)	3600	7200	13500	19800	27000	32400
Output Power (Mcal)	3090	6190	11610	17020	23220	27860
Pump Pressure (MPa)	1.20	1.20	1.20	1.20	1.20	1.20
Heavy Oil Consumption (Kg/H)	322	645	1209	1773	2419	2902
Natural Gas Consumption (Nm ³ /H)	364	728	1366	2002	2732	3278
Air Pressure (Kpa)	15~25	15~25	15~25	15~25	15~25	15~25
Gas Pipeline	DN65	DN80	DN150	DN150	DN200	DN250
Combustion Fan						
Flow Rate (m ³ /Min)	3635	7282	13659	20024	27318	32776
Air Pressure (Kpa)	2.80					
Motor Power (kw)	7.5	15	22	30	37	45

Some of Our Patents



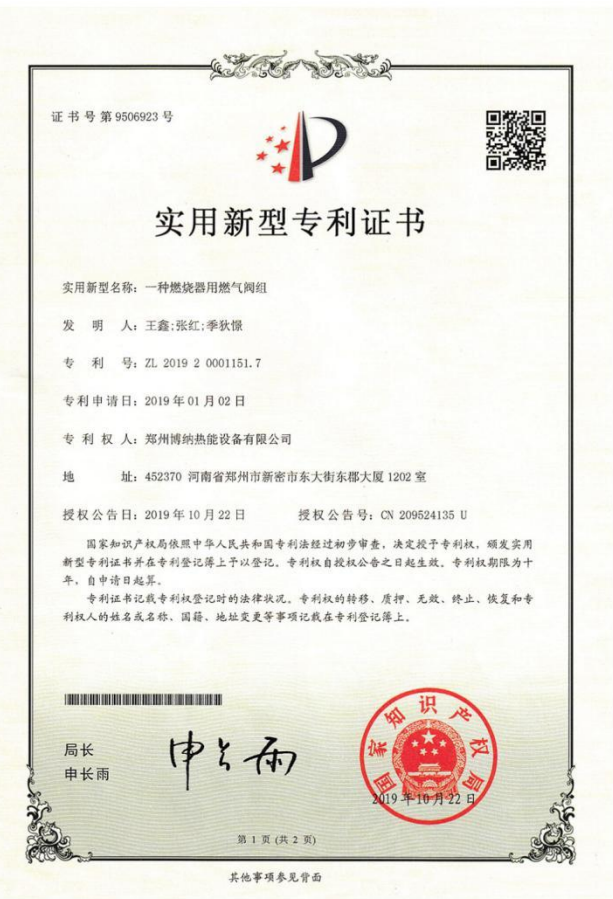

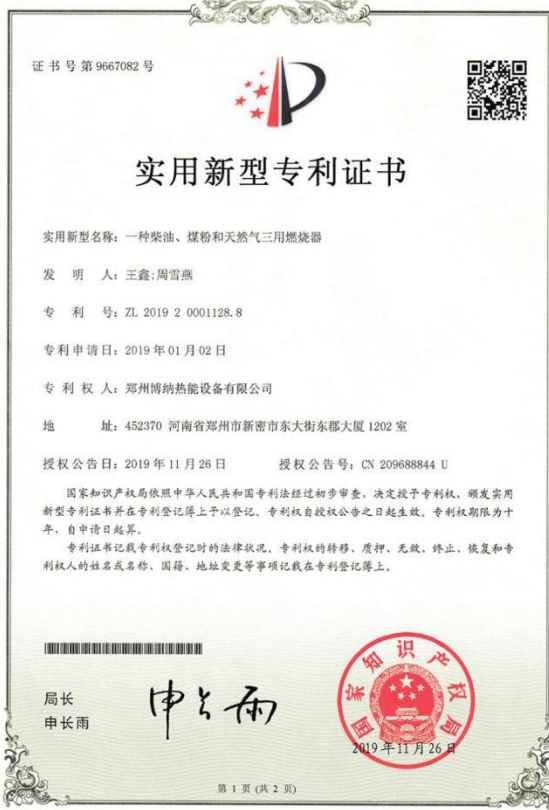
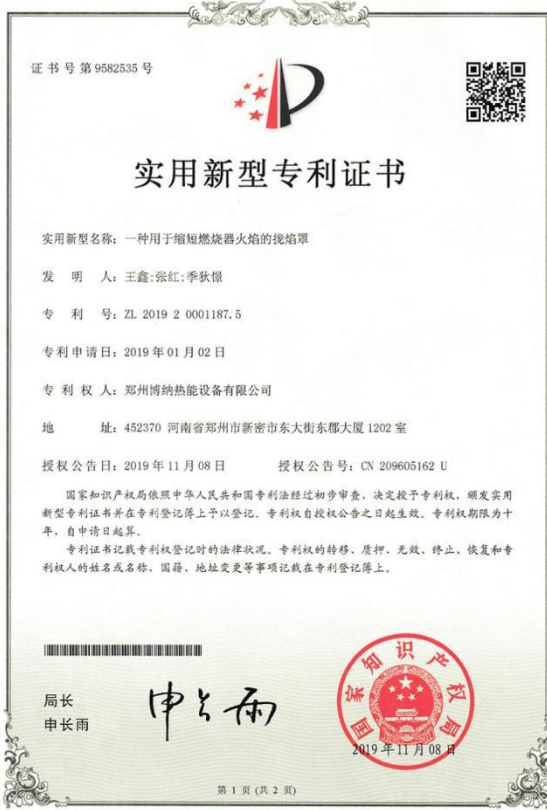

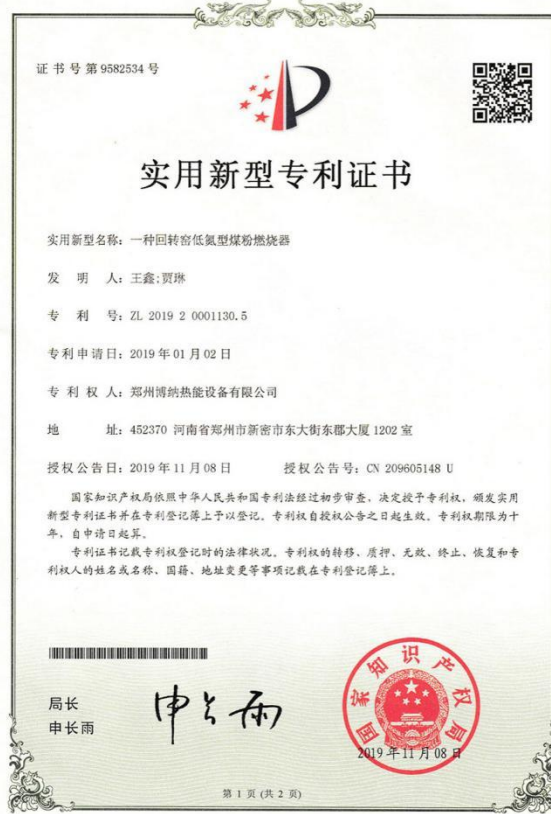
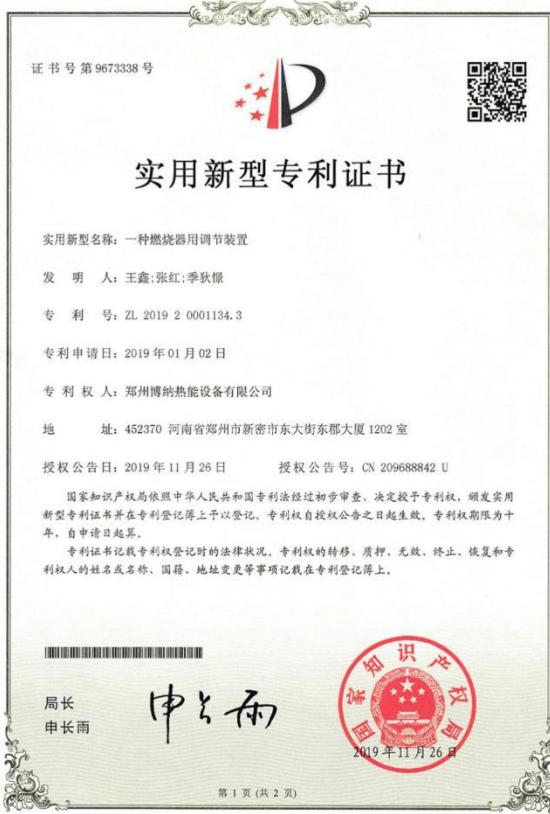

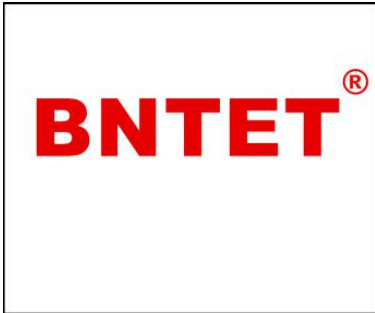

ZHENGZHOU BONA HEAT ENERGY EQUIPMENT CO., LTD.

Website: www.bntet-burner.com

Cell Phone: +86 156 3978 1876

WhatsApp/WeChat ID: +86 156 3978 1876

Email: info@bntet.com bona20@bntet.com

Factory Add.: Xinhua Road Office, Xinmi City, Zhengzhou City, Henan Province, China.

The data in this manual is just for reference, not strictly customized.

BNTET can customize products with special specification as your needing.